

Discover the  
people and  
places that make  
our country  
unique

# love the way™

(and the view of Canada too)



# The way travel is meant to be





Sit back, relax and get to know Canada in a way only the train allows. With plenty of room to chat, take a nap or soak in the scenery along the way, travelling by train is as comfy as it gets. Wherever you're headed, our friendly staff and the relaxing rhythm of the rails will make your trip one you'll want to remember. (Just like the views along the way.)



# Different ways to experience the country

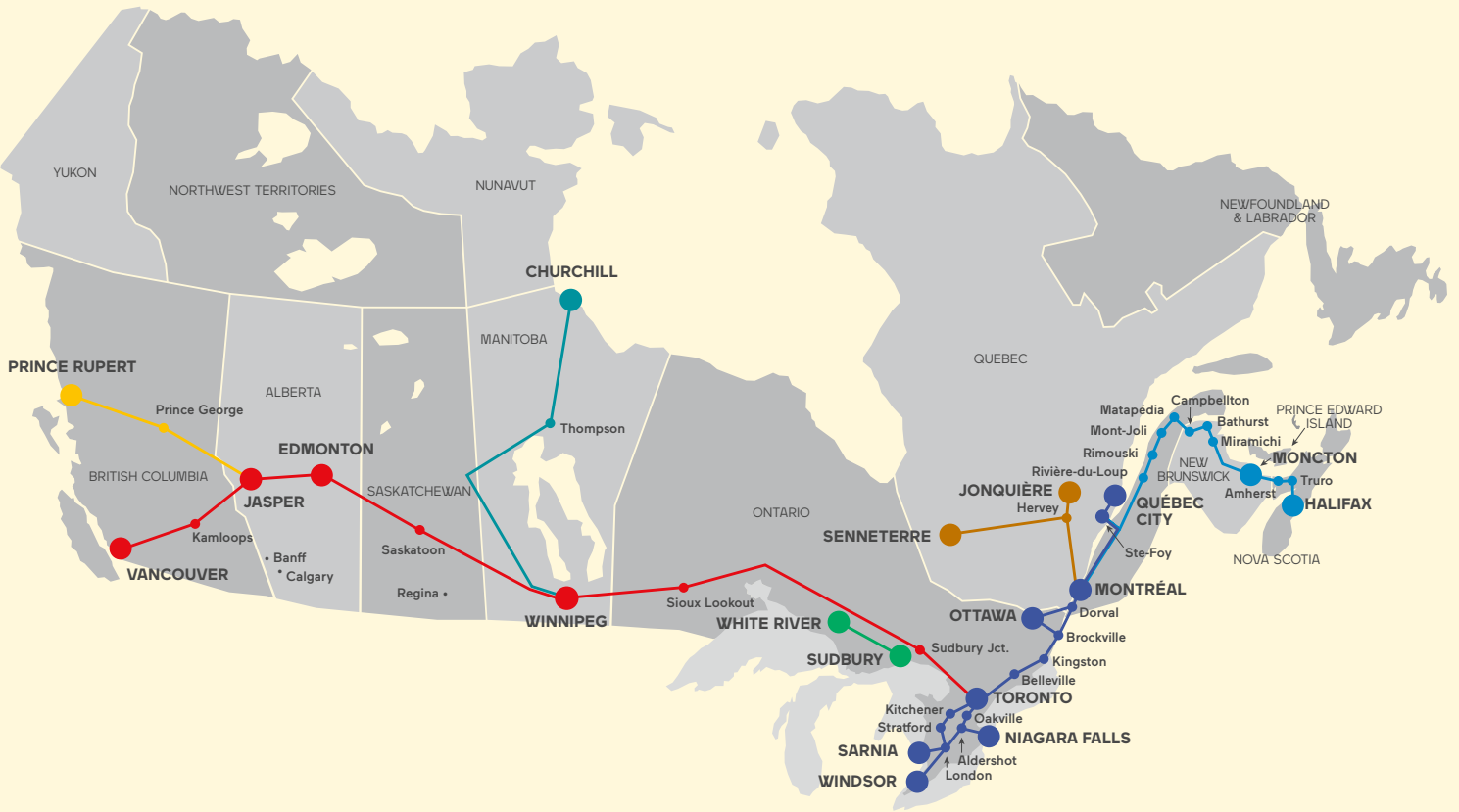

Jasper — Prince Rupert

**The Canadian**  
Toronto — Vancouver

Winnipeg — Churchill

Sudbury — White River

**Corridor**  
Québec City — Windsor

Montréal — Senneterre  
Montréal — Jonquière

**The Ocean**  
Montréal — Halifax





Canada by rail / VIA Rail Canada

THE CANADIAN

# The great western way

Toronto — Vancouver







Your adventure starts as soon as you step on board. The buzz of the city will be replaced by the sway of the train as you glide past forests, lakes and prairies. And, just when you think things can't get any better, you catch your first glimpse of the Rockies. (As amazing as you think they are and then some.) On the Canadian®, you'll become fast friends with Canada.

4 days /  
4 nights

4,466  
kilometres

Prestige,  
 Sleeper Plus and  
 Economy class

### Breathtaking views

Whether it's from the comfort of your cabin or from the scenic dome car, you'll see why we're called Canada's best window.

### Get comfy

With spacious seats, sleeper cabins and comfy lounges, you'll have everything you need to sit back and enjoy the ride.

### Meals worth travelling for

Get to know Canada on another level with freshly prepared meals showcasing Canadian and regional cuisines. Prepared by our very own chefs.<sup>1</sup>

### Upgrade your experience

All-inclusive meal and bar service, and a personalized concierge—Prestige class thinks of everything so all you have to do is enjoy the view.





# City getaways

Québec City ◌◌ Windsor







Whether it's a sightseeing city break or a refreshing weekend away, fighting traffic is no way to travel. Why not dial down the stress and dial up the convenience?

There's no better way to get to all the amazing festivals, museums and restaurants than downtown-to-downtown service.<sup>2</sup> Arrive in the heart of it all feeling relaxed and ready to explore.

1,765  
kilometres  
48 stations

Business and  
Economy class

## Downtown to downtown

Avoid traffic and parking headaches by getting right to the heart of the action.

## Hassle-free

Easy booking and express boarding.  
Spacious seats with legroom (a lot of legroom), onboard meals and a relaxing environment.

## A new generation of trains

A more comfortable, sustainable and accessible service, improving the environmental footprint.

## Stay connected

Free Wi-Fi, power outlets and cell phone use at any time.



# New Fleet

Introducing the new generation of trains that will run in the Québec City–Windsor corridor, forever transforming Canadians' travel experience.

A more comfortable, sustainable and accessible service that will reduce our environmental footprint through advanced energy-efficient technology.



**New trains arriving in 2023!**







**New fleet**



**New Fleet**

- / An Unparalleled Travel Experience
- / Barrier-Free and Fully Accessible
- / One of the most eco-friendly fleets in North America





THE OCEAN

# Maritime away time

Montréal — Halifax





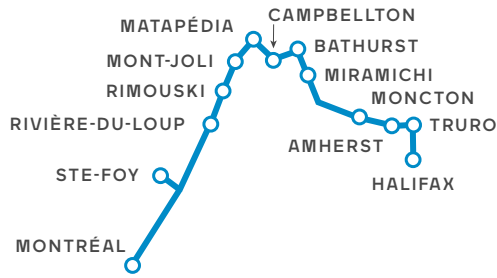

Imagine departing Montréal just as dusk is falling, shrouding the city skyline as you pull through the Montérégie Hills, distant lights marking the small towns you pass by on your journey east. As dawn breaks, the train descends the coast of Baie-des-Chaleurs, and soon you're in Moncton and then Halifax, where your Maritime adventure continues.

1 day /  
1 night

1,346  
kilometres

Sleeper Plus and  
Economy class

### Delicious regional specialties

Full catering service featuring tasty local ingredients.<sup>3</sup>

### Stay connected

Free Wi-Fi, power outlets and cell phone use at any time.

### Convenient connections

Take advantage of convenient ferry and bus connections to Saint John's and Prince Edward Island.



Back to map 



# Adventureful ways

## Jasper — Prince Rupert

This route follows beautiful rivers to British Columbia's rugged Pacific North Coast. Make the most of Jasper National Park's spectacular views, and find out what awesome really means when you take in the Canadian Rockies! You might even spot some local wildlife. Love the way, way north.

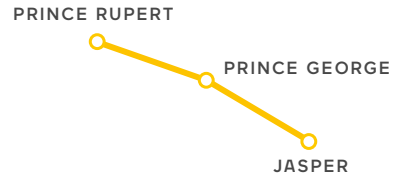

2 days<sup>4</sup>

1,160  
kilometres

Economy class





# Adventureful ways

## Winnipeg — Churchill

On this journey to the subarctic region of northern Manitoba, you'll be rewarded with the northern lights in winter, the chance to see polar bears in autumn, and the opportunity to spot belugas in summer.

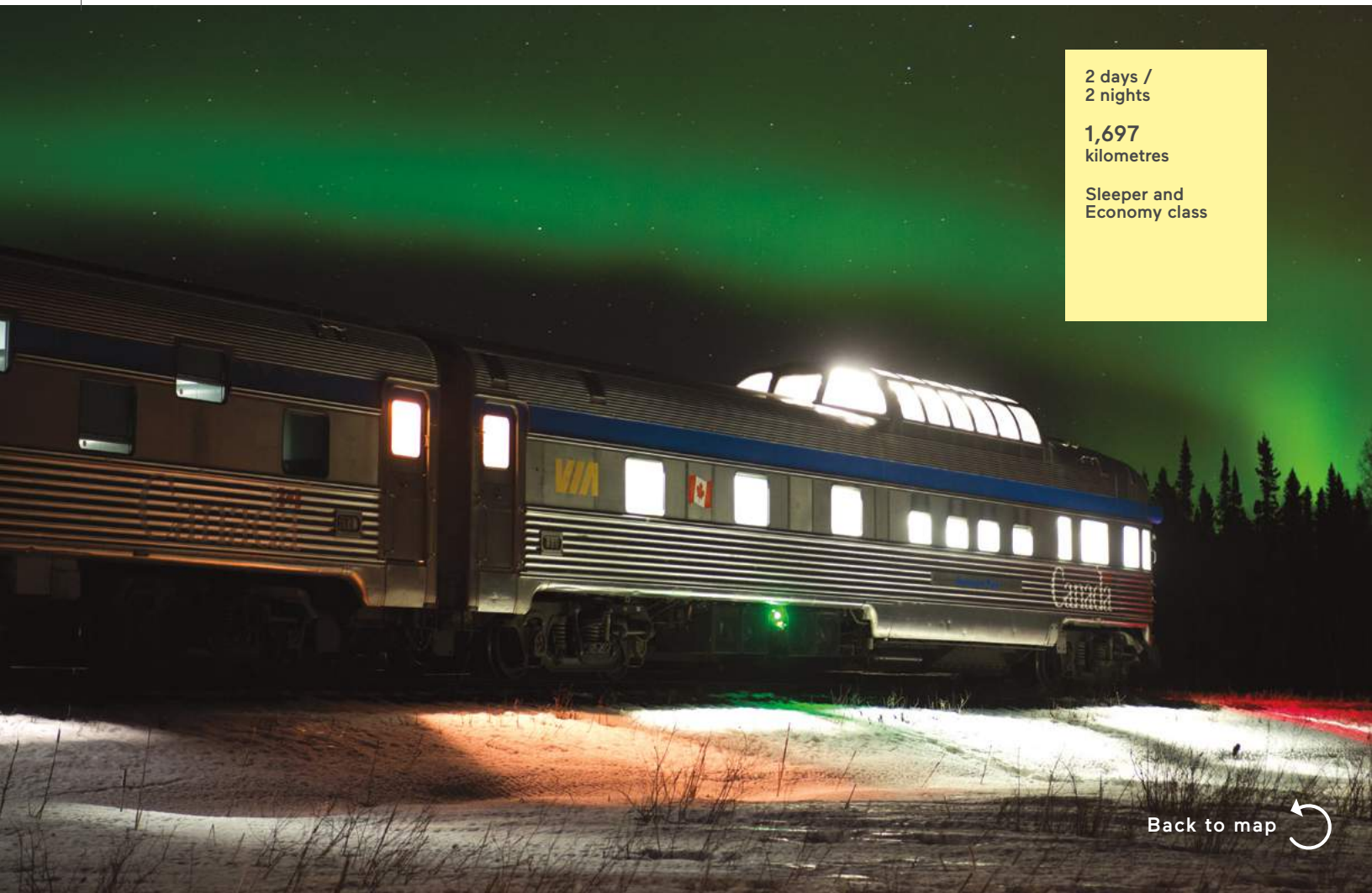
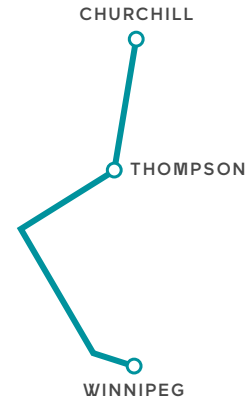

2 days /  
2 nights

1,697  
kilometres

Sleeper and  
Economy class



# Adventureful ways

Montréal — Senneterre

Montréal — Jonquière

This route boasts magnificent scenery—rugged and thickly forested landscapes, whitewater rivers, waterfalls, and hundreds of lakes. Adventure-seekers, hunters and fishing enthusiasts alike will love it.

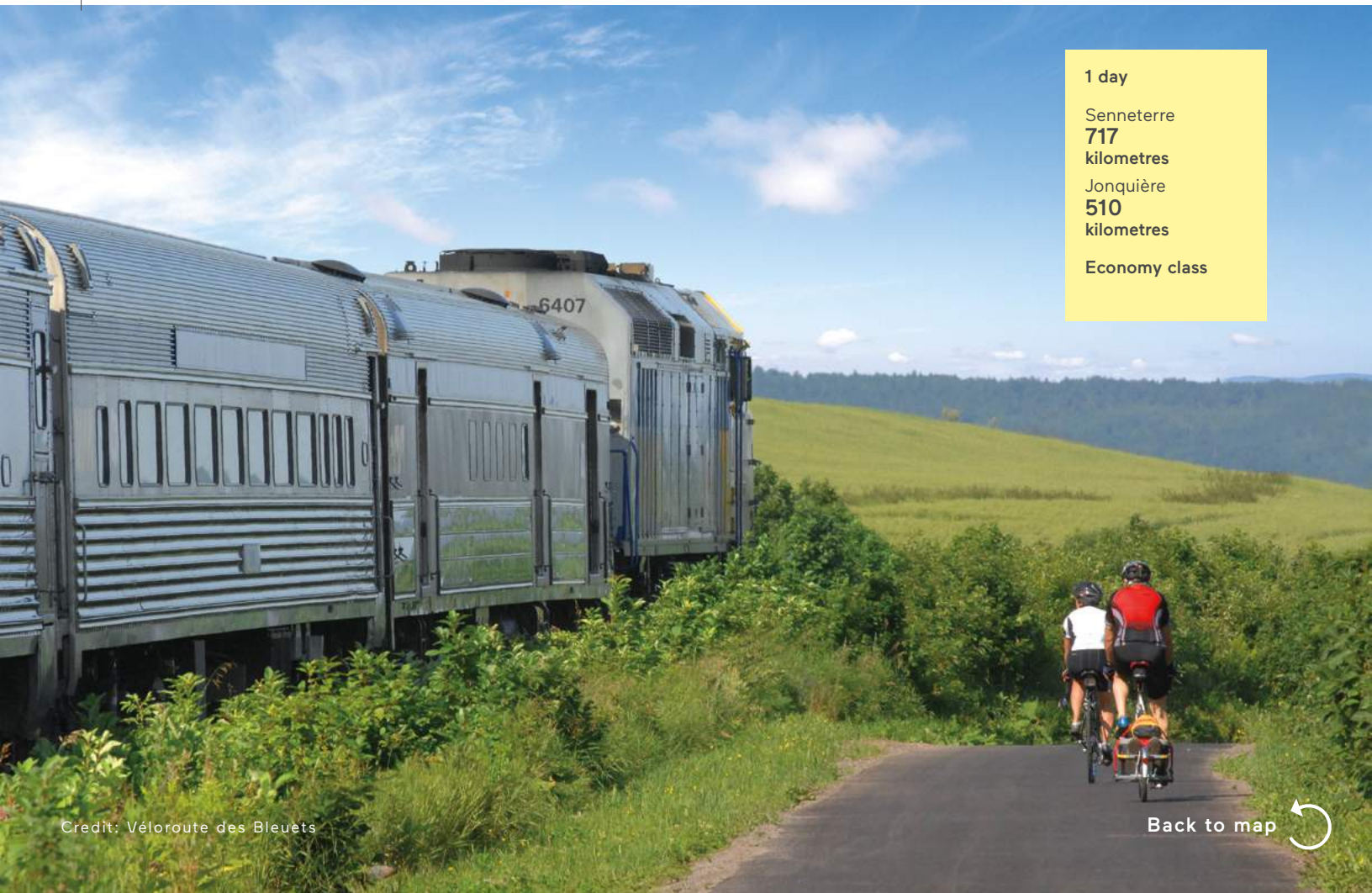

1 day

Senneterre

717  
kilometres

Jonquière

510  
kilometres

Economy class







# THE CANADIAN

Accommodations







## THE CANADIAN Dining car



### Dining car

The Dining car is just another one of the joys of train travel. Delight your senses in an incomparable setting.

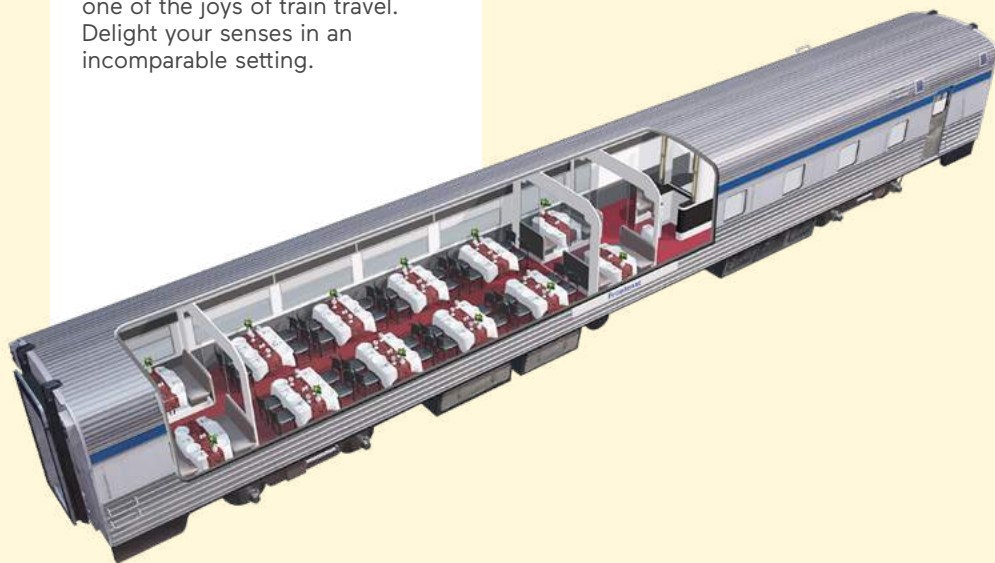





## THE CANADIAN Skyline car



### Skyline car

The Skyline car features a café-style dining area, kitchen and lounge, and a scenic dome section on the top floor, where the windows extend up to the ceiling—the perfect place to admire the breathtaking scenery as it unfolds.

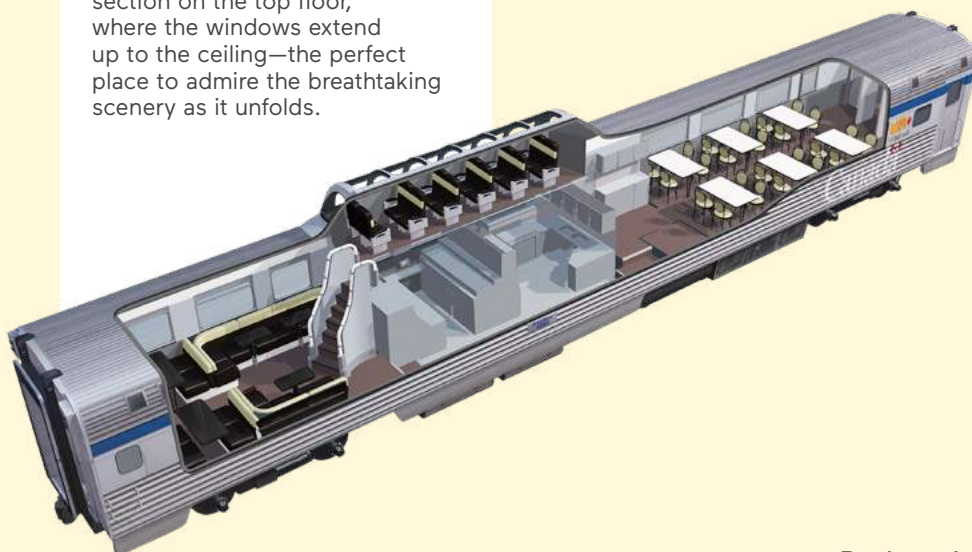





## THE CANADIAN Park car



### Park car

In this elegant and inviting lounge, passengers can enjoy non-alcoholic beverages and snacks, or simply take a seat and chat with the concierge or other guests in a laid-back atmosphere.

Car available to Prestige customers at all times and limited access for Sleeper Plus customers during peak season.

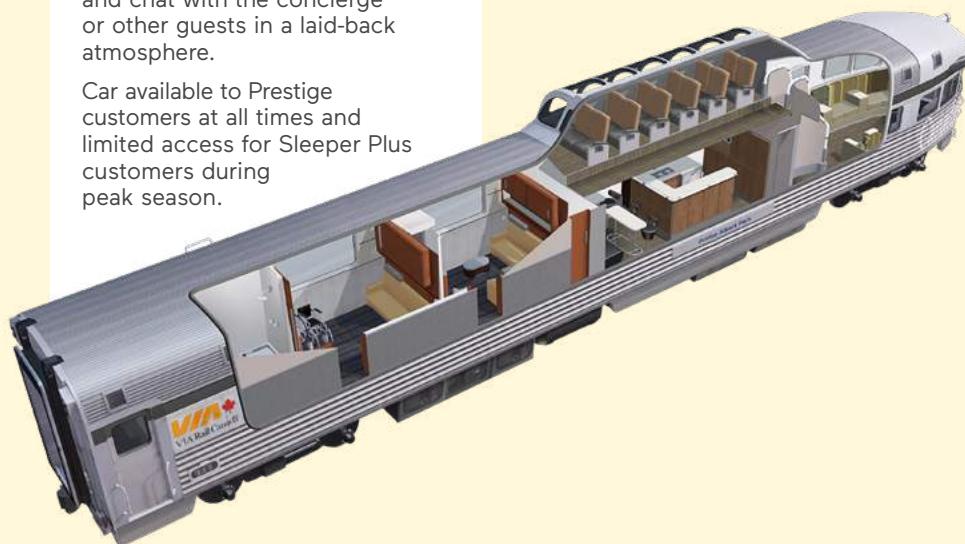





**THE CANADIAN**  
**Manor sleeping car**  
**Berths**



**Berths<sup>5</sup>**

Are open by day and consist of two couch-style seats facing each other. By night, berths convert to curtained, semi-private compartments with two stacked beds. Use of public washroom.

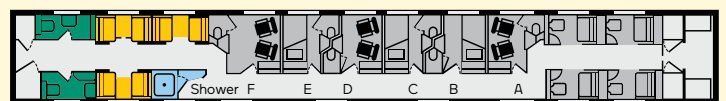
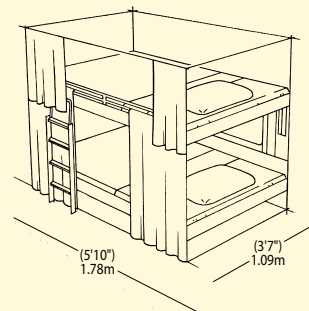

**Legend**

- Berth (upper and lower)
- Public washroom
- Shower

Limited space is available for carry-on baggage in Sleeper Plus class.

[Back to the Canadian section](#)





**THE CANADIAN**  
 Manor sleeping car  
**Cabin for one**



**Cabin for one<sup>5</sup>**

Private room featuring a small couch-style seat that converts into a bed, with a vanity and a concealed toilet.

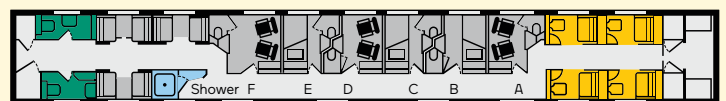
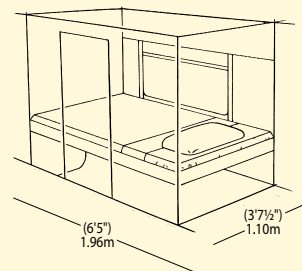

**Legend**

- Cabin for one
- Public washroom
- Shower

Limited space is available for carry-on baggage in Sleeper Plus class.

[Back to the Canadian section](#)





**THE CANADIAN**  
**Manor sleeping car**  
**Cabin for two**



**Cabin for two<sup>5</sup>**

Private room with two armchairs, two retractable stacked beds, a vanity and an ensuite toilet.

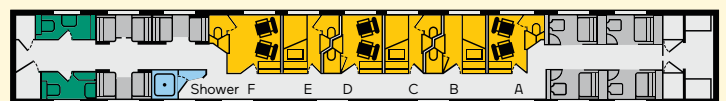
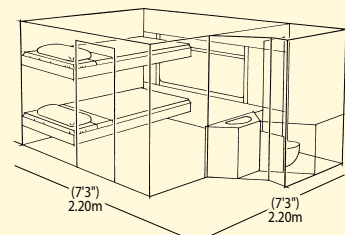

**Legend**

- Cabin for two
- Public washroom
- Shower

Limited space is available for carry-on baggage in Sleeper Plus class.

[Back to the Canadian section](#)





# CANADIAN Manor sleeping car Suites

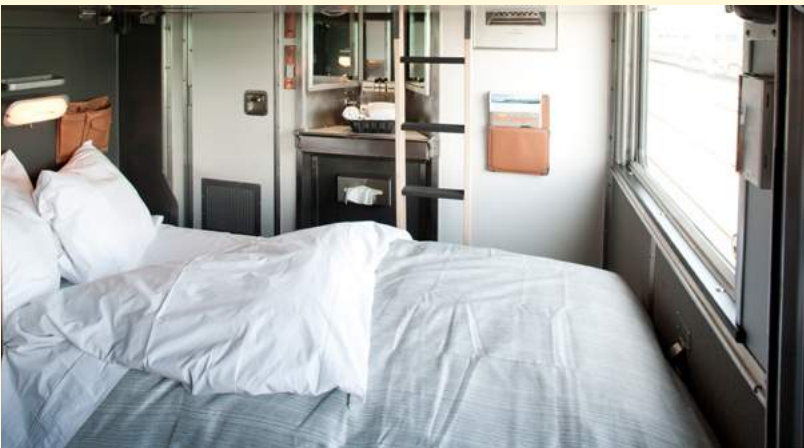

## Suites<sup>5</sup>

Two combined cabins for two (wall removed). The resulting room includes two ensuite toilets and two vanities. Sleeper Plus class comes with a private washroom.<sup>6</sup>

To accommodate up to four persons, please contact us.

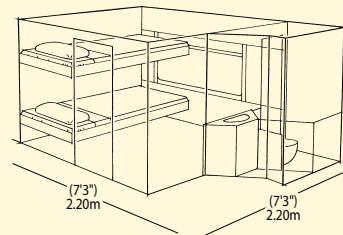

### Legend

- Bedrooms A+B, C+D and E+F can be combined into a suite.
- Public washroom
- Shower

Limited space is available for carry-on baggage in Sleeper Plus class.

[Back to the Canadian section](#)



## THE CANADIAN Prestige car Cabin for two



### Prestige cabin for two

Officially launched in spring 2015, it provides an unforgettable rail experience.

- Spacious cabin—50% larger than our cabin for two in Sleeper Plus class, with a wide viewing window that's 60% larger
- Modular L-shaped leather couch by day and a Murphy bed for two by night
- Private washroom with shower
- Flat-screen monitor with video selection
- Mini fridge stocked with a selection of beverages
- Complimentary bar service
- Electric radiant-heated cabin
- Priority seating in the dining car
- Dedicated Concierge attendant throughout the trip
- Activities such as wine tastings and interactive talks on local history, geography and culture



Limited space is available for carry-on baggage in Prestige class.

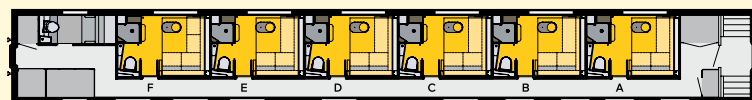
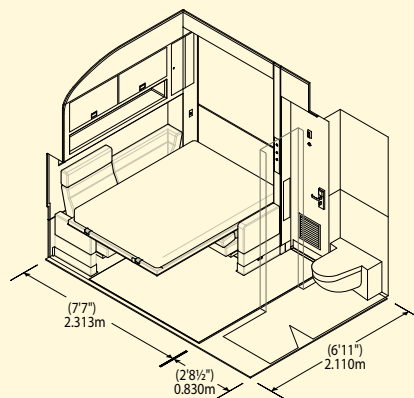

#### Legend

- Prestige cabin for two

[Back to the Canadian section](#)







# THE OCEAN

Accommodations







## THE OCEAN Service car



- Legend**
- Lounge
  - Accessible washroom

### Service car lounge

Relax and chat with other passengers in the service car lounge, complete with takeout counter and plasma screen.





## THE OCEAN Dining car

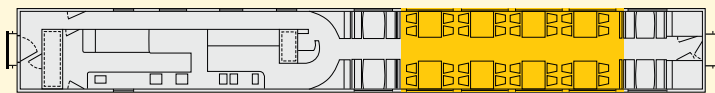

**Legend**  
■ Dining car

### Dining car

Savour your meals in our dining car while our attentive personnel see to your every need.

[Back to the Ocean section](#)





**BY OCEAN**  
**Renaissance car**  
**Cabin for two**



**Legend**

- Bedrooms 1-6 include a shower within the private bathroom
- Bedrooms 7-10 do not include a shower

Accommodations consist of cabins for two and one accessible cabin.

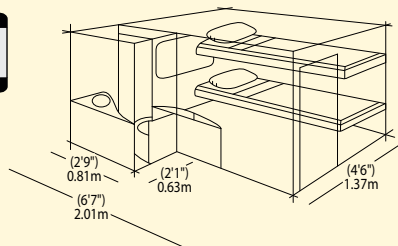

**Cabin for two**

Private room with a large sofa during the day, two retractable stacked beds at night and a private bathroom.



# Canada is waiting



6002 (11/2023)-INT-ENG

viarail.ca



\*Registered trademark owned by VIA Rail Canada Inc. <sup>TM</sup>Trademark owned by VIA Rail Canada Inc.

## Rail passes

VIA offers a variety of money-saving rail passes for travel on its network.

## Special savings for 60+, youth, travel groups and families

The train is the relaxing and affordable way for couples, families and friends to travel together. VIA offers discounts for travel groups of 10 or more, children, youth (12–25), and travellers 60 years of age or over, while infants under 24 months travel free when sharing a seat with an adult. Special rates are also available for companions of travellers with special needs.

## Accessibility

VIA Rail is responsive to passengers'

specific needs. Whether you are travelling in a wheelchair or have other particular requirements, we can accommodate you with a range of special services that vary according to station and train facilities.

Please check the availability of the service you need when you book, and provide your travel agent with all the relevant details at least 48 hours in advance.

## Baggage policies

Most long-haul trains have a baggage car, allowing you to check some baggage items. However, some short-haul trains have no baggage car, which reduces your baggage allowance. Please check allowance at time of booking.

## Travelling with pets

If your pet is small, it is possible to keep it close to you during the journey in a carrier that meets our carrier standards. Here is the information concerning the corridor train policy (Quebec City-Windsor). VIA Rail allows dogs and cats to travel in cars with their owners as long as the animals are small enough to fit comfortably in a carrier that meets our carrier standards. If you are traveling with a guide, service or emotional support dog, please visit our [Travel with a trained guide, service, or emotional support dog](#) section.

## Getaways

Book a train-hotel-activity package for worry-free travel. To find out more, visit [trainpackages.ca](#).

## Telephone (general information and booking)

From anywhere in Canada and the USA, call toll-free: 1 888 VIA-RAIL (1 888 842-7245) or TTY 1 800 268-9503 (hearing impaired)



For more information, visit [viarail.ca](#)

1. Prestige and Sleeper Plus classes only. 2. Ottawa's train station is located 6 kilometres from the city centre. 3. Sleeper class only. 4. Overnight accommodations and transfers in Prince George are not included. 5. Equipment is different on the Winnipeg–Churchill route and on the *Canadian* in peak season. 6. Not shown on diagram.